

Model DSP-Ex

Intrinsically Safe Portable Dewpoint Hygrometer

Ranges available between -110°C to $+20^{\circ}\text{C}$ (-166°F to $+68^{\circ}\text{F}$) Td

The **Model DSP-Ex** is a fully self-contained portable hygrometer from Alpha Moisture Systems which will deliver the most dependable moisture measurement in industrial and laboratory applications. Designed with the operator in mind, **Model DSP-Ex** is extremely easy to use and the digital **dewSMART™** technology ensures accurate and reliable readings over long periods with little or no maintenance. The incorporation of stainless steel quick connect fittings, together with the Desiccant Dry-down Chamber, allows rapid measurements which saves both time and cost.



Measuring instrument conforms with EN 61326

Fully Portable - Rugged - Fast Response - Stable - Reliable - Accurate - Easy to set up.

Comes with Anti-Static Carry Bag as standard.

Features

- Intrinsically Safe - ATEX Ex ia IIC T3 / T4 Ga
- Overall Range -110°C to $+20^{\circ}\text{C}$ Dewpoint
- User Friendly - Simple Operation
- Portable - Fully Self Contained
- Self-Diagnostics on Start-up
- Digital Indication
- Automatic Switch Off
- Quick Connect SS Coupling
- "C" Type Disposable Batteries
- Excess of 250 Hours of Continuous Operation
- Desiccant Dry-Down Chamber For Rapid Measurements
- Selectable Engineering Units in $^{\circ}\text{C}$, $^{\circ}\text{F}$, ppb(v), ppm(v), ppm(w), g/m^3 & lb/MMSCF

The **Model DSP-Ex** is certified intrinsically safe to Ex ia IIC T3/T4 Ga for use in hazardous areas without the need for any additional accessories. Designed to operate at atmospheric pressure, **Model DSP-Ex** is available in a total of 8 different ranges, encompassing an overall range from -110°C to $+20^{\circ}\text{C}$ dewpoint, with the display selectable in various engineering units: $^{\circ}\text{C}$, $^{\circ}\text{F}$ dewpoint, ppm(v), ppb(v), ppm(w), g/m^3 and lb/MMSCF. Parts per million (weight) can be programmed for gases other than those pre-programmed (Air, Ar, H_2 , SF_6 , CO_2 & N_2) by simply inputting the molecular weight of the gas under test.

Full interchangeability of the **dewSMART™** Sensor ensures guaranteed accuracy and reliability without the need to return the whole unit back to base for calibration and setup.

Model DSP-Ex is supplied ready for use with batteries installed, certificate of calibration traceable to National and International Humidity standards, two metres of stainless steel braided PTFE sample hose, instruction manual and an anti-static carrying case as standard.

Specifications

SENSOR TYPE

Aluminium Oxide Ultra High Capacitance Digital Sensor

INTRINSIC SAFETY CERTIFICATION

Code : Ex ia IIC T4 Ga (Ta = -20°C to +37°C)

Ex ia IIC T3 Ga (Ta = -20°C to +50°C)

Certificate No.: Sira 02ATEX2132X



RANGE

Six different ranges encompassing an overall range of -110°C to +20°C dewpoint (-148 to +68°F).

Corresponding ranges in ppm(v), ppb(v), ppm(w), g/m³ & lb/MMSCF. Parts per million (weight) programmable for different gases.

DISPLAY

Industrial specification, 2 x 20 Character LCD with programmable bright & dark contrast.

DISPLAY RESOLUTION

0.1°C dewpoint / 0.1ppm

POWER SUPPLY

9V DC - Six "C" type disposable batteries.

BATTERY LIFE

In excess of 250 hours during continuous operation.

ELECTRONICS ACCURACY

Better than ± 1% of range.

WARM UP TIME

15 Seconds

SENSOR CALIBRATION ACCURACY

Better than ±2°C dewpoint. All units supplied with certificates documenting factory calibration against known moisture levels traceable to National & International humidity Standards.

REPEATABILITY

± 0.1°C dewpoint.

TYPICAL RESPONSE TIME

95% of reading within 20 seconds in normal operation.

OPERATING CONDITIONS

Temperature : -20°C to +50°C

Humidity : 0-98% RH, Non-condensing

Storage Temperature : -50°C to +70°C

Operating Pressure : Atmospheric to 0.5 barg

ELECTROMAGNETIC COMPATIBILITY (EMC)

Immunity : Complies with EN 61000-6-1:2007

Emissions : Complies with EN 61000-6-3:2007

FLOW RATE TO SENSOR

2 to 20 litres/minute

CONNECTIONS

Swagelok quick-connect stainless steel coupling and 0.25" overall diameter compression tube fitting.

WARRANTY

2 years from date of delivery against faulty material or workmanship.

Desiccant Dry Down Technology

The Desiccant Head Assembly

Keeping the sensor dry between tests ensures that the DSP-FCI is always ready to carry out rapid spot checks. The unique design of the Desiccant Head achieves this by surrounding the sensor with desiccant before the head is lifted for sampling.

At no time is the sensor allowed to come into contact with ambient air. The chamber is also designed so that the void space and chamber wall surfaces are purged with sample gas, before exposure of the sensor, so giving faster, more accurate and reliable results.

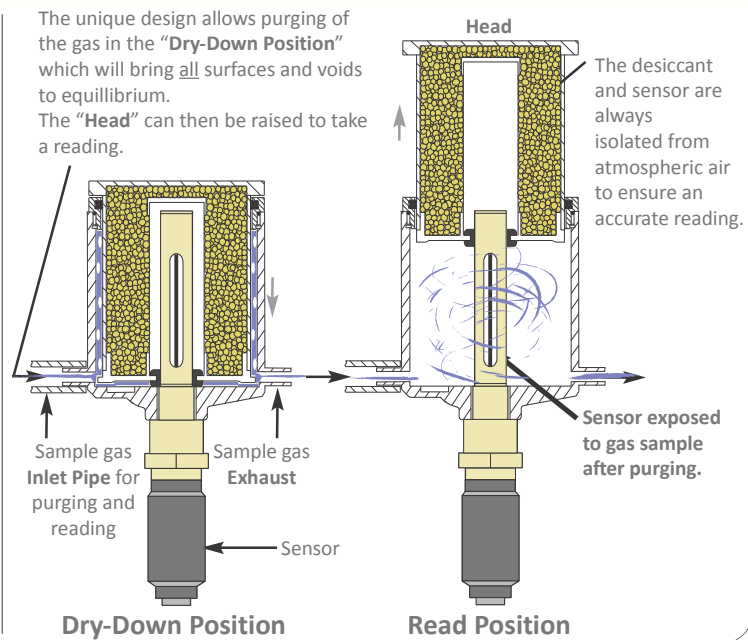

Corrosive Gases

The Sensor should not be exposed to corrosive gases (or corrosive contaminants in the main gas sample) as they would chemically attack the sensor and render it useless.

Examples of such gases are mercury (Hg), ammonia (NH₃), chlorine (Cl₂) and wet acid vapours i.e. acid vapours in gas with moisture content greater than 100ppm(v). Strong oxidising agents such as ozone (O₂) should also be prevented from coming into contact with the sensor.

Weights and Dimensions

Model DSP-Ex Dewpoint Analyser

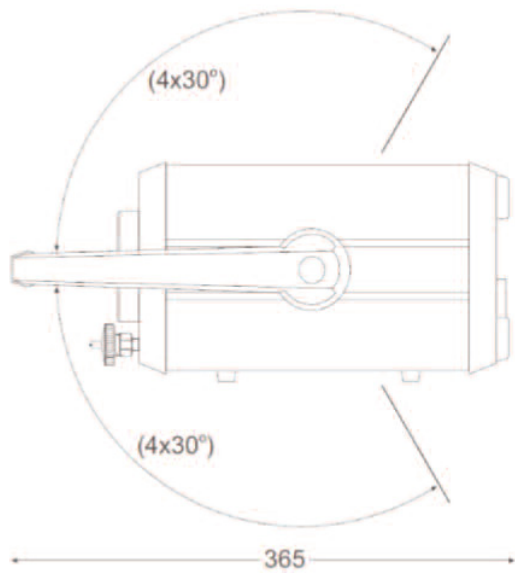

All dimensions in millimetres

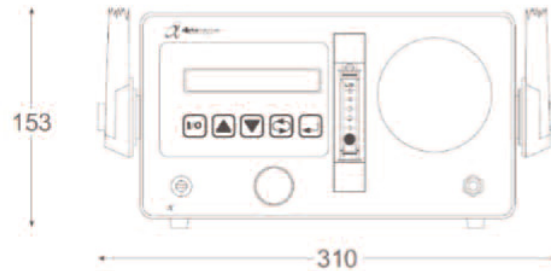

Weight unpacked - 5.8 Kg (net)

Export packed - 8.2 Kg (gross)

How to Order - Step 1 of 2

Select a Range Below

Model DSP-Ex + [XX]

PURPLE	-110 to +20°C	PL
SILVER	-110 to -20°C	SR
BLUE	-80 to +20°C	BL
GREY	-80 to 0°C	GY
RED	-80 to -20°C	RD
YELLOW	-60 to 0°C	YW
GOLD	-50 to +20°C	GD
GREEN	-30 to +20°C	GN

Example : If your requirement is for a Portable dewpoint meter with an operating range of -80°C to -0°C dewpoint then please order as : Model DSP-EX-GY

Your DSP-EX includes the following parts:

- 2m of high quality stainless steel braided PTFE hose with 1/4:NPT tapered fitting and female quick connector.
- Pressure calculator.
- Adjustments screw driver.

Ex Related Products

For more information on our specific Ex product range, please contact us or visit www.amsystems.co.uk

Below is a list of Ex products:

- SADPmini-Ex Hand Held Dewpoint Meter
- AMT-Ex Dewpoint Transmitter
- DS1200-AMT-Ex Dewpoint Hygrometer
- SADPμ & SADPμ-D Portable Dew point Analysers.
- Dewpoint Sample Systems
- Plus made to order solutions.

How to Order - Step 2 of 2

Order accessories - Below is a small selection, please see website for more at www.amsystems.co.uk



Transit Case
Order Part No. CAS010



Standard Filter Unit
Order Part No. AFU



Needle Valve
Order Part No. PPE016

Product specification may be subject to change, without prior notice, as part of our ongoing product development programme.

1677 Model DSP-Ex pd161112-iss-2



CERTIFICATE No. FM35600
BS EN ISO 9001:2008



Alpha Moisture Systems Limited. Registered Office: Alpha House, 96 City Road, Bradford, BD8 8ES

Registered in England and Wales No. 3902302 - VAT Registration No. GB 607 2075 63 - WEEE Producer Registration No. WEEE/EA0067TX



North American Distributor

Instrumentation Solutions For The Process Industry

Northvale, NJ 07647 DeltaInstrument.com Phone (201) 768-7200