

Users Manual

Pury 250e

Gas Purification System



Union Apparatebaugesellschaft GmbH

P.O. Box 21 10 51
D – 76185 Karlsruhe
Zeppelinstrasse 42
D 76185 Karlsruhe
Germany
Phone +49 721 – 95243 – 0
Fax +49 721 – 95243 – 33
e-mail info@union-apparatebau.de
www.union-apparatebau.de

Represented in China by:



Anshan Union System Control Co., Ltd.

192#A Yualin Road, Tiedong District, Anshan, China
Tel: 0086 412 5814665
0086 412 6356000
Fax: 0086 412 5824215
e-mail: ashwang@mail.asptt.ln.cn

Represented in North America by:



Delta Instrument LLC

Delta Instrument LLC

148 Veterans Drive
Northvale
NJ 07647
Phone: 201-768-7200
Fax: 201-768-5020
Web: DeltaInstrument.com
Email: info@DeltaInstrument.com

Welcome

Thank you for specifying a Pury 250E for your online process measurement application.

Please read this manual and follow all directions before installation and use of this gas purification system.

Unpacking and initial inspection of this unit requires only normal precautions and procedures applicable to the handling of analytical equipment. All shipping containers should be carefully checked for any included accessories. Check the shipment against the packing slip and any system arrangement drawings to ascertain that the shipment is complete.

The unit was carefully inspected and calibrated at the factory. Check the shipment for possible damage incurred during transit. If there is any sign of visible damage to the crate or hidden damage inside the shipment, notify the carrier and the factory immediately as the equipment warranty does not cover damage in shipping.

In the event of trouble during start-up, please contact a factory representative and inform them of the model and serial number of the unit, plus a full description of the problem. Note: The factory will not be responsible if the customer should attempt repair of the unit during the warranty period without first following any detailed factory instruction.

All possible care has been taken in the publication of this user's manual but Union, its agents and distributors, accept no liability for any inaccuracies or omissions that may be found. This manual reflects the state of the product at the issue date below but further refinements may mean that the manual does not fully reflect your particular system.

Before start up and use of the Pury 250E please take time to carefully review this manual and its contents. Observe all safety notes, warnings, cautions and notes – see Chapter 1 for more details.

Union Apparatebau GmbH reserves the right to make changes to this publication and the product that it describes without notice.

Contents

1.	Safety Instructions	5
2.	Introduction	6
2.1.	General information	6
3.	Installation	7
3.1.	Overview	7
3.2.	Installing the gas lines	8
3.3.	Installing the condensate line.....	9
3.4.	Electrical connections	9
4.	Commissioning	12
4.1.	Control menu	12
5.	Measurement Principle	14
5.1.	Functional description	14
6.	Maintenance	15
6.1.	Capillary cooler with filter	15
6.2.	Cooling block with fan	16
6.3.	Condensate pump	16
7.	Decommissioning	17
8.	Trouble Shooting	18
8.1.	Cooling device does not switch on.....	18
8.2.	Cooling block does not cool.....	18
8.3.	Condensate carry-over to the gas outlet.....	18
9.	Circuit Diagrams	19
9.1.	Control board terminals	20
10.	Technical Data.....	21
10.1.	System specifications	21
10.2.	Condensate volume.....	21
10.3.	Water vapour	22
11.	Spare Parts.....	23

1. Safety Instructions

Before start up and use of the Pury 250E, please take time to carefully review this manual and its contents. Observe all warnings, cautions and notes.

Warning:

Disconnect the main power switch before any service work is carried out.

Before maintenance or repair work on the power or high voltage ignition equipment, the following points need to be observed.

After switching off the main power wait at least 5 min. for any stored voltage charge to dissipate to zero.

During start up, service or abnormal conditions there is a danger of a very small release of unburned gas from the outlet of the system to the atmosphere.

If process gas has any toxic components please follow all personal safety rules. Any small release of gas during start-up is highly diluted with cooling air.

All electrical connections to line power must be carried out by a qualified electrician. The analyzers internal electrical components are wired in accordance with NEC, VDE and International standards. Check the power supply voltage, details can be found on the technical data label inside the door.

Only qualified personnel should install the gas connections in accordance with all local codes and ordinances.

The Pury 250E operates over a specified ambient temperature range. and installing the unit directly outside is not recommended, since damage may occur from adverse weather conditions if an outdoor shelter is not used.

Caution:

Caution is necessary during installation because pressurized flammable gases are connected to the sample conditioner and any installation work performed by the customer must conform to all applicable local and national codes. All internal sample gas components have been leak tested at 1.5 times the normal operating pressure during assembly at the factory. After installation, the entire sample gas system should be pressurized and tested for leaks before use.

When planning the installation, local site conditions must be taken into account so consult any hazardous area regulations for applicability.

2. Introduction

2.1. General information

Sample gases found in industrial processes are often saturated with water and contain dust and other components undesirable to the measurement process. The Pury 250E gas purification system dries and cleans gas in such a way that it can be processed for measurement in a CWD2000 gas calorimeter or other on-line process analyzers.

Undesirable components may include:

Dust

Naphtha

Hydrogen Sulfide

Water

And other additional components such as oils, tars and acids.

The components will differ depending on the family of gases, and the unit is primarily designed for use with coke oven and blast furnace gases. Naturally, other gases can be dried and cleaned. Special applications may require the supply of a heated sample gas line or additional filtration.

The Pury 250E consists of a stainless steel heat exchanger that cools the process gas to between 1 and 5 °C. The water removed from the sample gas by condensation is collected in a container and is drained using a peristaltic condensate pump. The refluxed water dissolves acid and removes dust in the sample gas by creating small droplets on the stainless steel filter elements.

The cooling system of the Pury 250E is connected directly to the process gas line. If the process gas is saturated with water at higher than ambient temperature, then a heated line should be installed to avoid condensation and possible blockage in the line.

The optimum conditions for use are within an ambient temperature range of +5 to +45 °C. Beyond these limits, the system efficiency is reduced and below 0°C there is a real risk of damage from the condensate freezing.

Maintenance of the Pury 250E is simple and limited to cleaning and or replacement of the stainless steel filter elements and checking the operation of the condensate pump. The cooling unit, control elements and the condensate pump are protected by a compact indoor rated enclosure. The condensate pump operates periodically and drains the collected condensate.

The maximum sample gas flow is 250 litres per hour with a pressure drop of 5-10 mbar, depending on gas consumption.

3. Installation

Carefully remove the Pury 250E from its packaging material and check for any loose items. The installation location must be clean, dry and sufficiently ventilated as the fan draws in 50 m³ of air per hour from the surrounding environment.

3.1. Overview

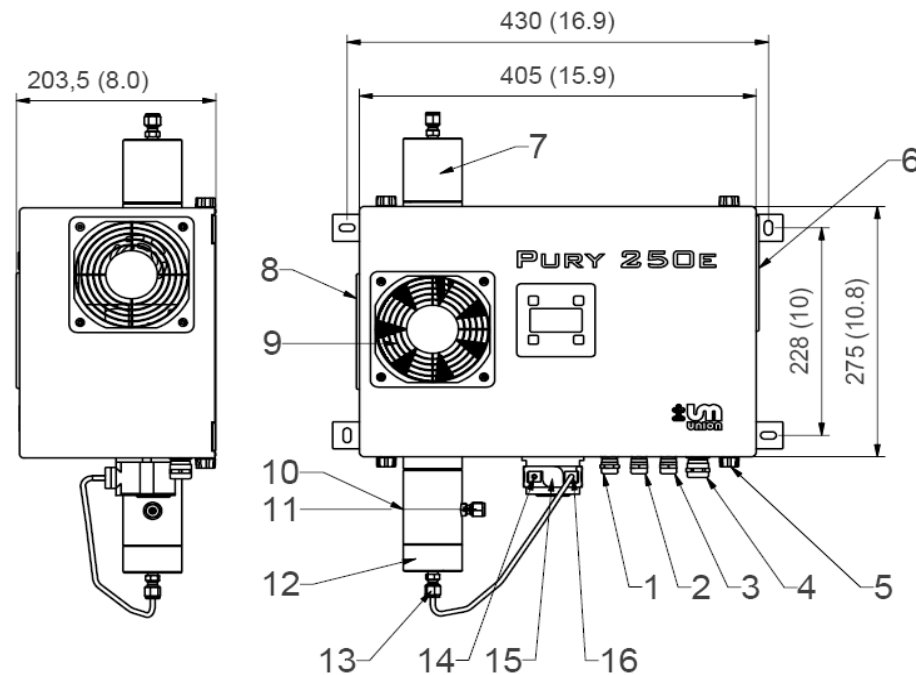

Figure 1 : Pury 250E system overview

1	Relay output	9	Cooling fan
2	Relay output	10	Filter housing
3	Relay output	11	Gas inlet
4	Line Power	12	Condensate container
5	Holding screw	13	Condensate outlet
6	Fan grille	14	Condensate pump delivery side
7	Gas outlet	15	Condensate pump
8	Fan grille	16	Condensate inlet

The Pury 250E is an indoor wall mounted unit and must be installed in a vertical position well away from sources of heat. There must be sufficient space around the enclosure's ventilation ports to allow cooling air to freely circulate and heated exhaust air to escape..

If installed outside, the Pury 250 e must be fully protected from the effects of weather conditions.

3.2. Installing the gas lines

If a heated line is installed, insulate the line where it connects to the unit. If a S/S line is used, thermal decoupling may be required at the sample gas input to avoid any overheating due to heat conducted from the heated line.

Gyrolok 6x1 (1/4" tube) threaded connections are provided. The dimensions have been adapted for the required consumption and pressure drop. 6x1 (1/4") SS tubing is recommended for the process gas outlet at the top to the capillary cooler. If necessary, an additional filter can be connected at this point.

The sample gas line is connected to the calorimeter via a pressure regulator or directly depending on the available supply pressure after the gas cooler. The additional pressure regulator is required if the process gas pressure is above 15-18 mbar (6 – 8" H2O).

The pressure drop through the unit is about 5 mbar. If the specified pressure at the gas outlet is too low for the analyzer a sample gas pump must be used. This can be supplied as an option on request. The pump is designed for a delivery volume of 250 l/h max.

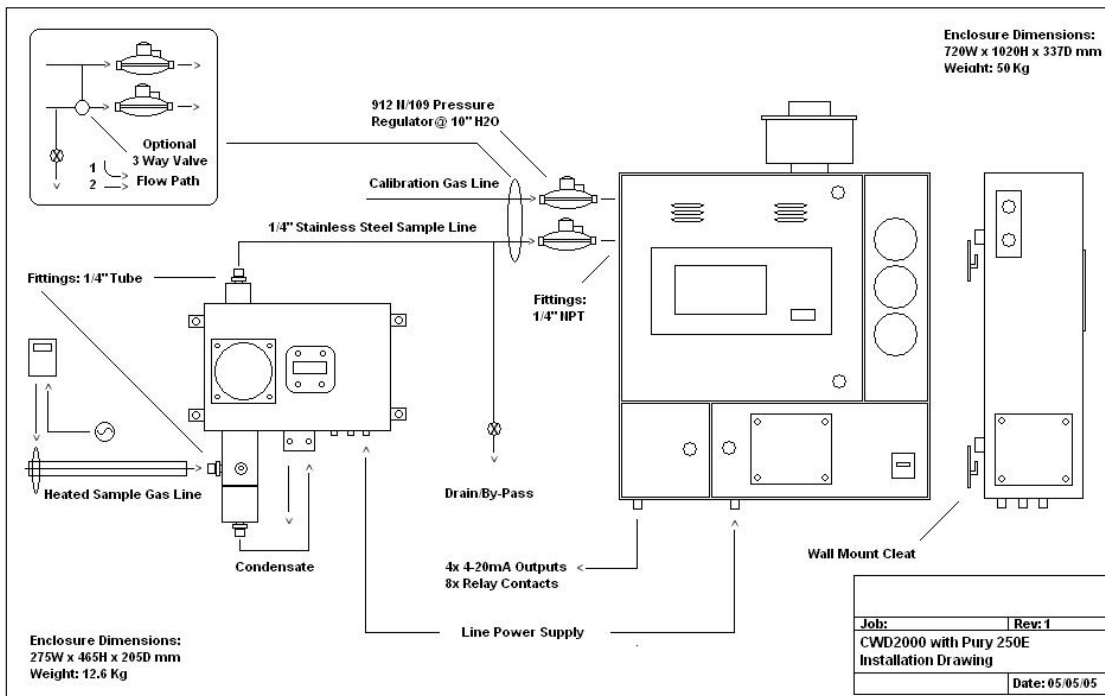

Figure 2 : Typical gas connection diagram

3.3. Installing the condensate line

To allow all the condensate to be pumped out of the system the condensate line must be always be above freezing point.

The Condensate pump is connected with a tube .runs from the condensate collection container to the pump to an outside location. The condensate can be discharged or pumped back into the process using locally sourced tubing.

All connections must be checked for leaks.

The mechanical installation of the Pury 250E is now complete.

3.4. Electrical connections

Prior to commissioning, please first check the power supply voltage matches with the voltage specified on the specification rating plate.

Remove the 4 attachment screws on the enclosure to gain access to the connection terminals.

The enclosure cover should be removed and the power supply cable passed through the PG cable glands and connected to the unit as shown in the terminal block drawing. After power is applied the system will start operating, the cooling system will start and the cooling fan will begin to draw air through the enclosure.

As standard, 230 V 50 Hz AC is supplied but. other voltages, e.g. 115 Volt 60 Hz are available on request. The operating voltage must be specified prior to delivery as the units are voltage specific and not switchable in the field.

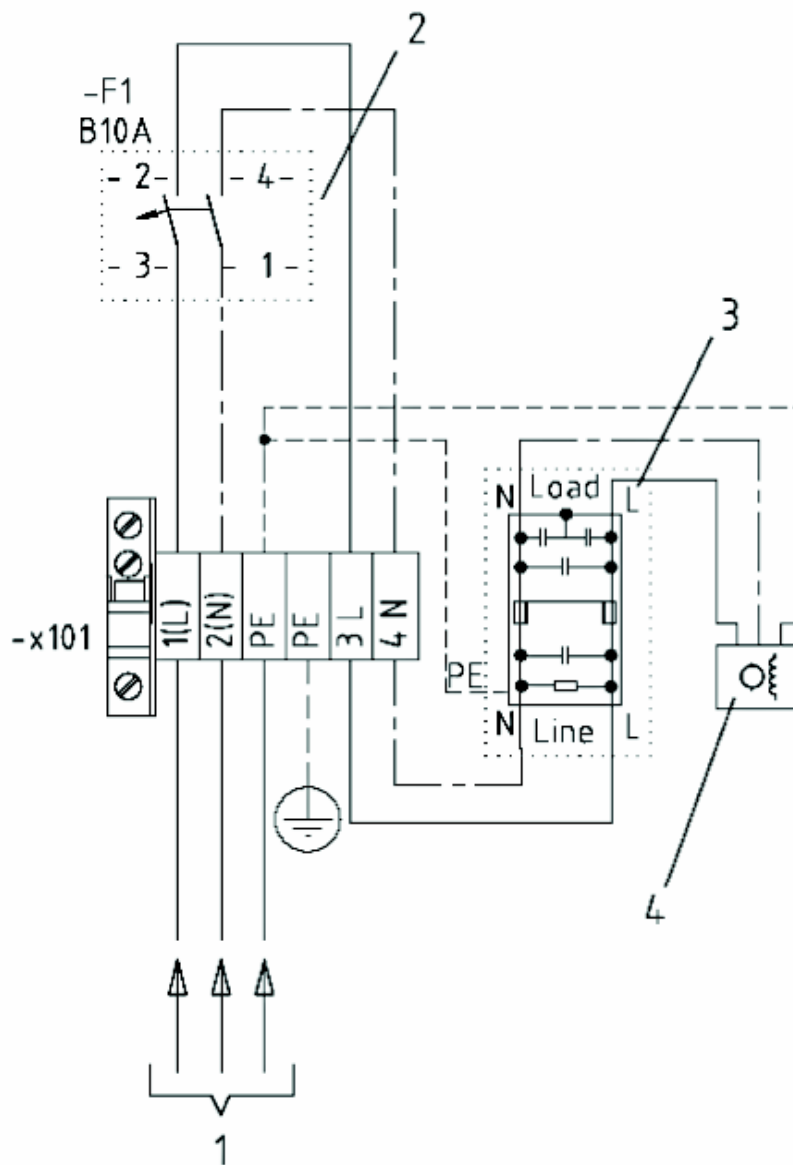

Figure 3 : Electrical connection diagram

- | | | | |
|---|-------------------------|---|----------------------|
| 1 | 230 or 115V 50/60 Hz | 3 | Line power filter |
| 2 | Safety shut-down switch | 4 | Mains supply circuit |

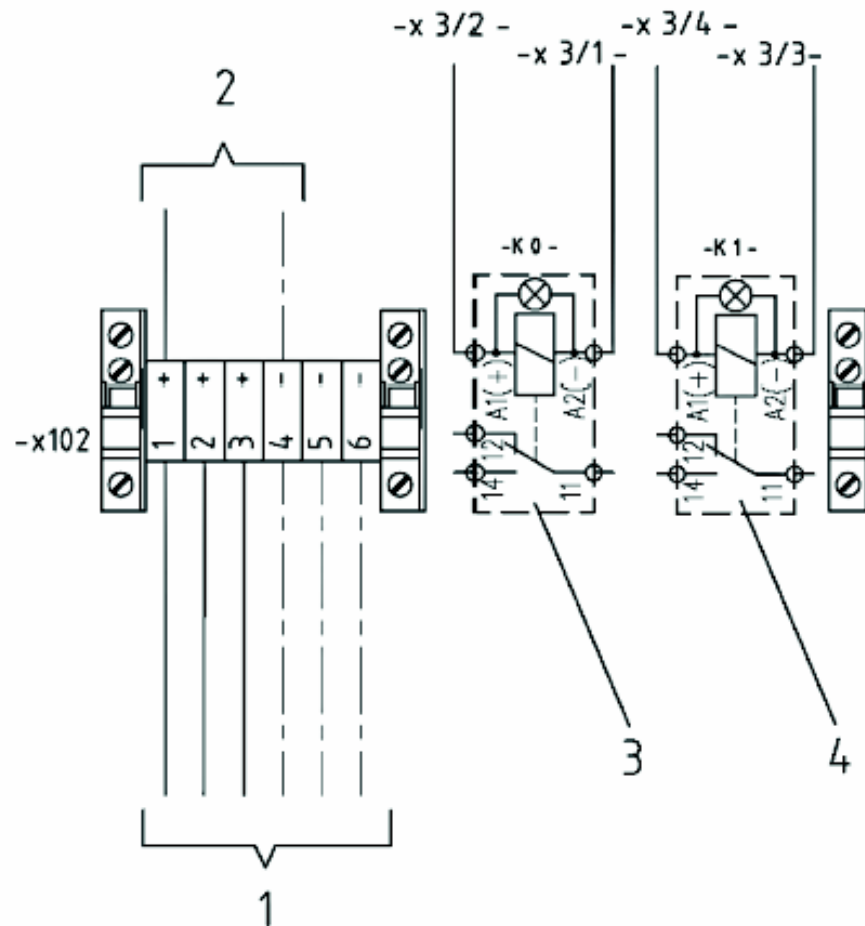

Figure 4 : Internal 24 Volt power supply diagram

1	24 Volt DC	3	Relay
2	Input 24 V line power circuit	4	Cooling fan

The line power circuit can be connected with 230 or 115 Volts (Check the rating plate for the correct voltage). The internal power supply for the condensate pump, peltier cooling elements and electronic control system uses 24 Volts DC. The internal wiring shown in this diagram is shown for informational purposes only.

4. Commissioning

As soon as the cooler is connected to line power, the Peltier element will start cooling. The display will immediately show the cooling temperature. After approximately 15 minutes the cooler will reach its temperature set-point.

4.1. Control menu

In this chapter, the temperature control and duty cycle for the condensate pump are discussed. Default values are set at the factory that immediately guarantee normal operation and some adjustment may eventually be required to suit local conditions.

The "▲" and "▼" keys alter the values in the display to + and – values. The "⏏" key takes you one level higher in the menu. The "⏏" key takes you one level lower in the menu.

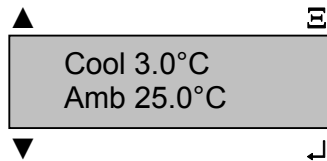

Cool 3.0°C and Amb 25.0°C shows a cooler temperature of 3°C at an ambient temperature of 25°C. The "⏏" key takes you to the next level down in the menu.

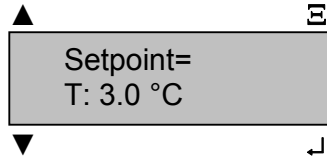

Setpoint = 3.0°C shows the cooling set-point temperature. By pressing the "▲" and "▼" keys, the temperature set-point can be altered. A value 3.0° C is the default value. The "⏏" key takes you to the next level down in the menu.

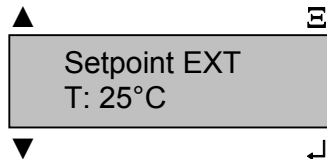

Setpoint EXT T:25°C displays the cooling fan activation temperature and the fan switches on if the ambient temperature exceeds this value. The "⏏" key takes you to the next level down in the menu.

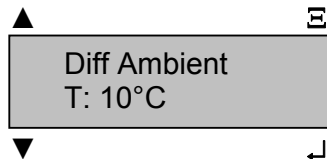

Diff Ambient T:10°C determines the difference between ambient and cooler temperature. In this example, the difference is 10°C. This difference indicates the degree of drying and the 10°C (preset in the factory) may not be reduced or the unit will switch "off". Below this point there is a risk that even after the condensate key displays "off", the selected temperature <10°C will not be reset.

This relay contact can be used, for example, in conjunction with a contact input in the CWD 2000 Gas Calorimeter to alarm a system shut-down or used by the customer as a discrete alarm contact. The maximum value of Diff Ambient is 25°C and any higher value is not permitted by the system. The "└" key takes you to the next level down in the menu.

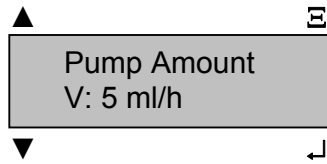

Depending on the dew point of the gas, more or less liquid condensate will be removed after drying. The volume of condensate removed is indicated in ml/h and the accumulated condensate volume can be calculated by using the tables in Chapter 10, The condensate pump will then automatically discharge the required volume of condensate from the system, at predetermined intervals.

Note: The correct input of ml/h is worth calculating since it will extend the operating life of the condensate pump.

From the lowest menu level, the higher menu levels can be accessed via the "ε" key, until the start menu is once again reached.

5. Measurement Principle

This chapter describes the various functions of the Pury 250E.

5.1. Functional description

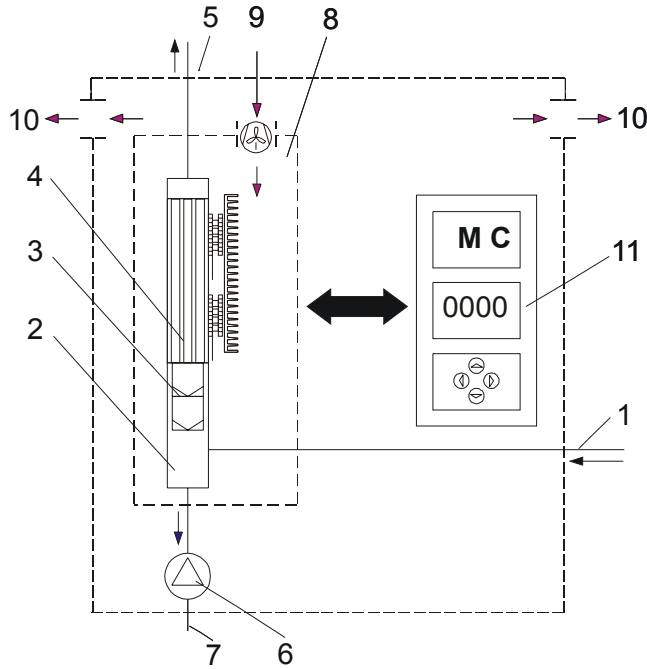

Figure 5 : The main components of the Pury 250E

1	Gas inlet	7	Condensate outlet
2	Condensate collector	8	Peltier cooler
3	Filter unit	9	Fan inlet
4	Gas cooler	10	Fan exhaust
5	Gas outlet	11	Control unit
6	Condensate pump		

The gas flows into the condensate collector (2) from line (1). Condensed water from the process gas line is separated from the gas and then it flows through the filter separation unit (3). The filter unit consists of both coarse and fine mesh filter elements. Coarse particulates such as naphtha, hydrogen sulfide and dust are washed out by the reflux action of the liquid condensate. The condensate from the gas cooler (4) means that the filter is always wet and this increases the cleaning effect as the return condensate also cleans the filter. The dried and conditioned gas is supplied from the outlet (5). The condensate pump (6), removes the condensate from point (7) up to a maximum pressure of 800 mbar. The enclosure has three cooling air openings (9 and 10). The thermal energy from the Peltier elements is removed via forced draft and a body (8) with cooling fins. The control unit (11) is used to set the dew point set-point value and the condensate pump duty cycle.

6. Maintenance

During maintenance, all installation and process specific safety instructions must be observed before work can begin. Maintenance may only be carried out by trained personnel. Following maintenance, the assembly must be leak tested before being returned to service.

6.1. Capillary cooler with filter

The wire mesh filter inserts can be steam cleaned or exchanged depending on the level of contamination. The O-ring seals must also be carefully checked for damage and replaced if necessary.

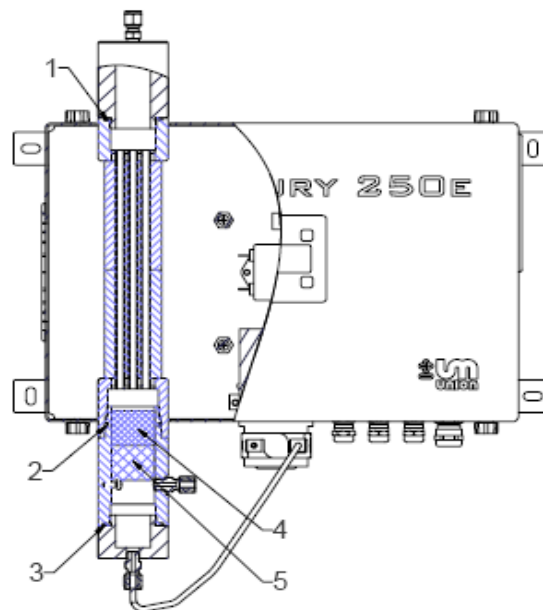

Figure 6 : Capillary cooler with filter unit

- | | | | |
|---|---|---|---------------------------|
| 1 | Top section with O-ring NBR 45x3mm | 4 | Wire filter- fine mesh |
| 2 | Filter seat with O-Ring NBR 43x3mm | 5 | Wire filter – coarse mesh |
| 3 | Condensate collector with O-Ring NBR 43x3mm | | |

6.2. Cooling block with fan

Clean the cooling body (6) as necessary for peak performance.

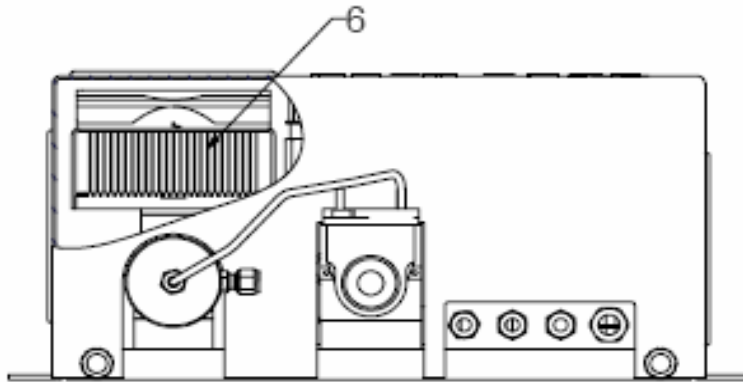

Figure 7 : Cooling block with finned cooling body (6)

6.3. Condensate pump

The tubing on the peristaltic pump should be replaced annually depending on the pump duty cycle. Note: This is an important safety item since a pump tube failure may allow gas to escape since it is at line pressure at this point.

7. **Decommissioning**

Switch the unit off and drain the condensate, the installation location for the gas cooler must be frost-free. At temperatures below 0°C, condensate may freeze and destroy the tubing and filter assemblies.

8. Trouble Shooting

8.1. Cooling device does not switch on

1. Check whether the device has been correctly connected to the line power supply.
2. The Pury alarm contact does not release the calorimeter for operation. The ambient temperature is too high. Either reduce the ambient temperature or program the Diff Ambient function to "off" .

8.2. Cooling block does not cool

1. The heat exchanger is fouled with dirt and must be cleaned.
2. The fan is delivering insufficient cooling air. Check fan.
3. Peltier cooling elements may be damaged.

8.3. Condensate carry-over to the gas outlet

1. The heat exchanger is filled with condensate. Condensate is not being removed by the pump.
2. Check pump tubing.
3. Increase condensate pump duty cycle.
4. Gas supply flow rate is too high. Check if the sample gas flow rate exceeds the 250 l/h maximum. Reduce flow volume.

9. Circuit Diagrams

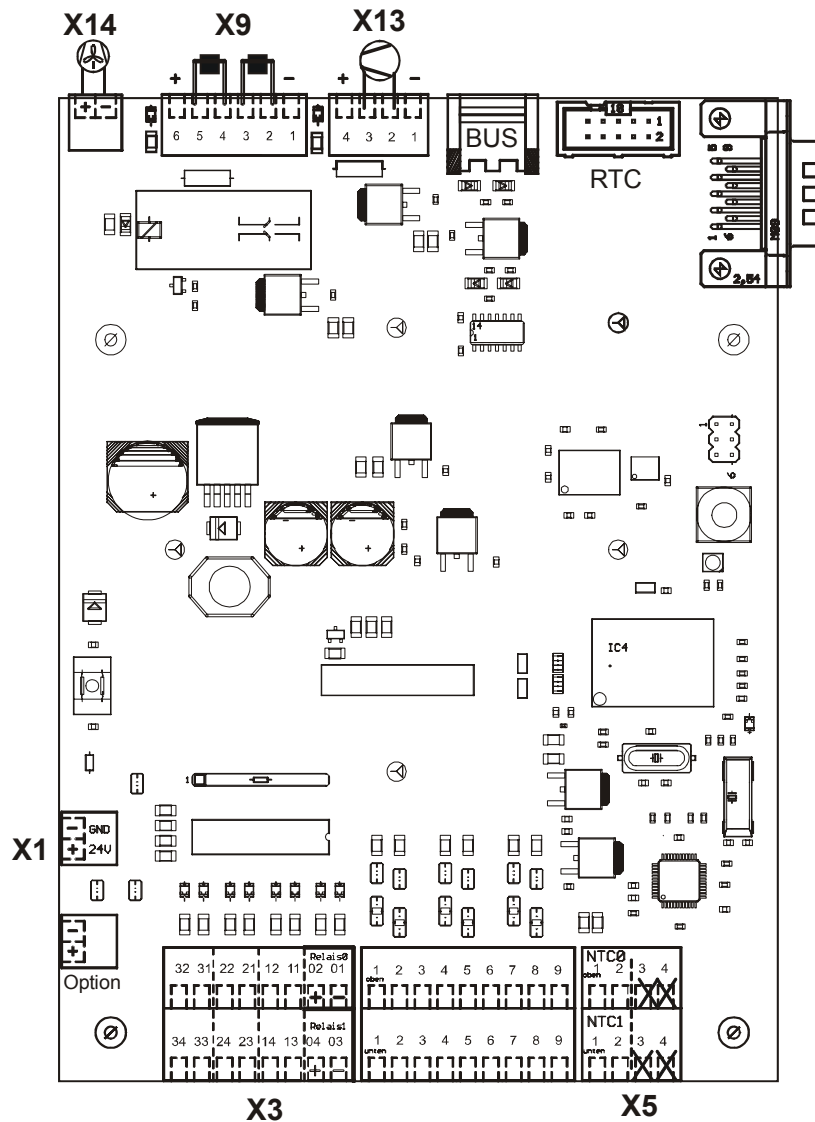

Figure 8: Terminal block connections

X1	Power supply 24 V DC	X14	Fan Peltier elements
X3	2 x Relay control 24 V	X 9	Peltier elements
X5	NTC Temp. Gas/Air	X13	Condensate pump

9.1. Control board terminals

Plug	Pin	Signal	
X1		+24VDC	Power supply control board
X1		GND	Power supply control board
X3	01	GND	Relay 0
X3	02	+24V	Relay 0
X3	03	GND	Relay1 cooling fan
X3	04	+24V	Relay1 cooling fan
X5	1	NTC0	Gas temperature
X5	2	NTC0	Gas temperature
X5	1	NTC1	Ambient temperature
X5	2	NTC1	Ambient temperature
X9	1	GND	Power supply Peltier elements
X9	2	GND	Peltier element I
X9	3	12V	Power supply Peltier element I
X9	4	GND	Peltier element II
X9	5	12V	Power supply Peltier element II
X9	6	24V	Power supply Peltier elements
X13	1	GND	Power supply condensate pump
X13	2	GND	Condensate pump control
X13	3	24V	Condensate pump control
X13	4	24V	Power supply condensate pump
X14		+24VDC	Fan Peltier elements
X14		GND	Fan Peltier elements

10. Technical Data

10.1. System specifications

Power supply:	230V, 47-63Hz, 900VA 115V, 47-63Hz, 900VA
Weight:	12.6 kg (28lb)
Dimensions in mm:	455 x 275 x 202 (18"H x 11"W x 8"D)
Protection type:	IP 22 (NEMA 12)
Effective cooling capacity:	20 Watt at a delta T of 25°C
Ambient temperature:	+5 to 45 °C (40 to 113°F)
Max. temperature difference:	25 °C
Pressure drop:	approx. 5- 10 mbar (2-4"H ₂ O)
Max. gas flow:	250 l/h (8.75 CFH)
Permitted gas pressure:	800 mbar (11.6 PSI)
Hose pump:	Delivery pressure 800 mbar max.

10.2. Condensate volume

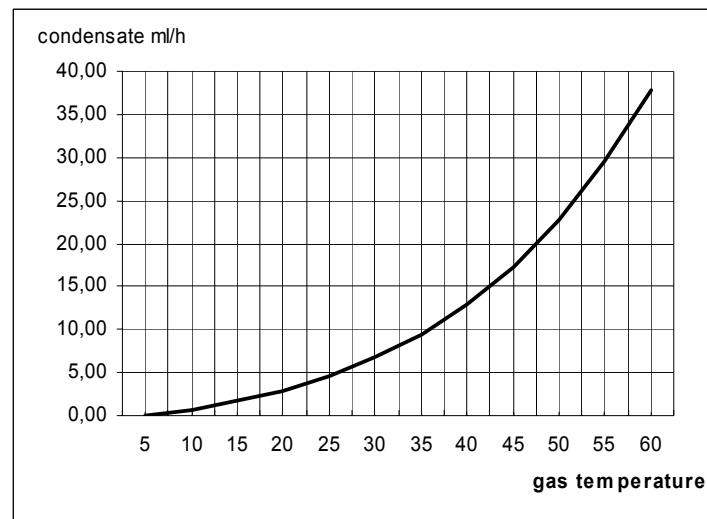

This graph shows the condensed water volume at 250ml/h gas at a dew point of 3°C

10.3. Water vapour

Water vapour condenses from the process gas at a defined temperature and pressure. The graph shows the relationship between water vapour at various temperatures and the curve shows the point at which the sample gas can either hold or condense water vapour, also referred to as the dew point temperature. Note: The addition of sulfur components can also raise its dew point.

If the gas temperature is above ambient temperature a heated sample line has to be installed. The hose temperature needs to be at least 10°C above the temperature shown for the % water vapour in the process gas. Note: Reducing the gas temperature in an unheated line from 100 to 20°C, drops out 97% of the water.

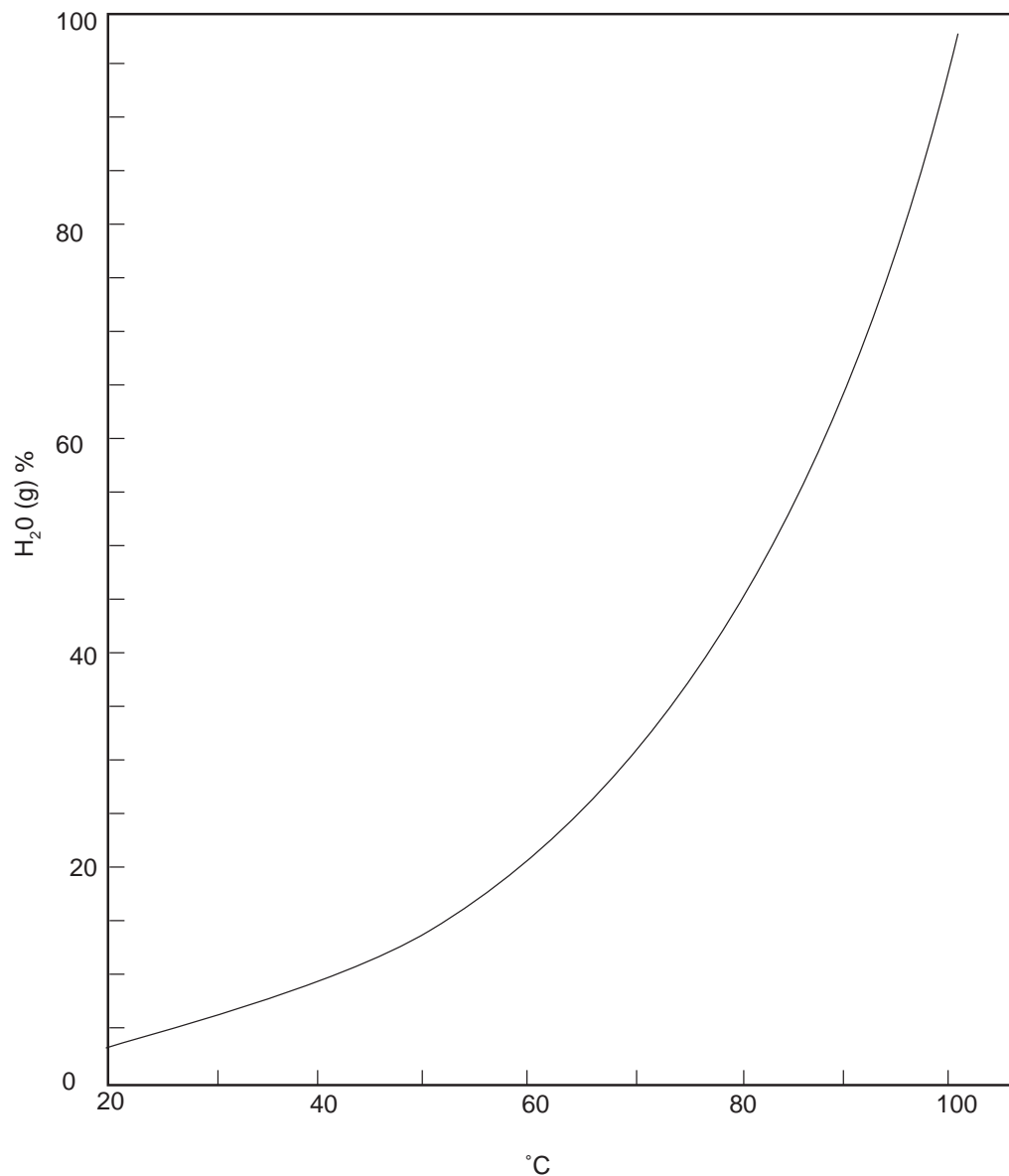

This graph shows water vapour condensation point from 0 to 100°C

11. Spare Parts

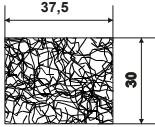
	<p>Filter cartridge AD = 37.5 mm / height 30 mm Density: 0.5 g/cm³ Material: 1,4841 Weight: 17g</p>
<p>Description: Filter cartridge fine</p>	

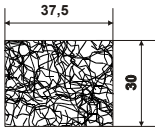
	<p>Filter cartridge AD = 37,5 mm / height 30 mm Density: 1.0 g/cm³ Material: 1,4841 Weight: 33g</p>
<p>Description: Filter cartridge coarse</p>	

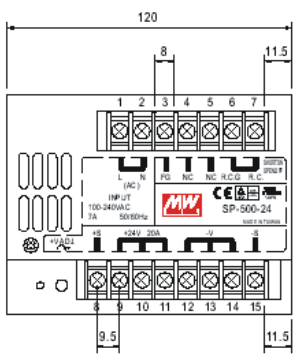
	<p>Mains supply circuit type SP-500-24 Supply voltage: 88-264 Volt 47-63 Hz Output voltage: 24 Volt DC Output current: 20 A Weight: 1,900 Kg</p>
<p>Description: Mains supply circuit SP-500-24</p>	

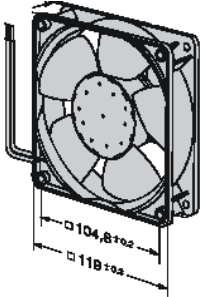
	<p>Fan type 4314NH Supply voltage: 24 V DC Power consumption: 4.5 Watt Bearing: Ball bearing Nominal speed: 3150 U/min Weight: 0.230 Kg</p>
<p>Description: Fan 24V</p>	

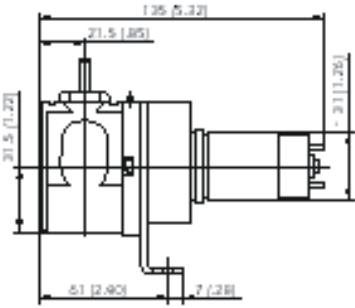
	<p>Hose pump Supply voltage: 24 V DC Power take-up: 2 Watt Operating speed 30 rpm Volume flow 25ml/min Weight: 0.600 Kg</p>
Description: Hose pump R25/24VDC	

	<p>Pump hose Hose material: Noroprene Dimensions 3.2mm/1.6mm Weight: 0.100 Kg</p>
Description: Pump hose	